

Ritter®

# Installation and Operation Manual

## 319 Power Examination Table



MA382400

**Important  
Information**  
*Page 2*

**Installation**  
*Page 3*

**Description**  
*Page 5*

**Components  
Overview**  
*Page 7*

**Controls &  
Indicators**  
*Page 8*

**Operation**  
*Page 10*

**Operator  
Maintenance**  
*Page 21*

**Calling For  
Service**  
*Page 24*

**Specifications**  
*Page 24*

**Limited  
Warranty**  
*Page 26*

# Owner's Product Identification

(information that you will need to provide for servicing - key information is highlighted)

**Date of Purchase**

**Serial Number**

Name of Owner / Facility / Department

**Model Number**

Name of Authorized Ritter Dealer

Telephone # of Authorized Ritter Dealer

Address of Authorized Ritter Dealer

**MODEL AND SERIAL  
NUMBER LOCATION**



MA382500

# CONTENTS

<b>IMPORTANT INFORMATION .....</b>	<b>2</b>
Scope and Purpose of This Manual .....	2
Intended Use of Product .....	2
Safety Instructions .....	2
Explanation of Safety Symbols and Notes .....	2
<b>INSTALLATION .....</b>	<b>3</b>
Unpacking .....	3
Leveling The Table .....	4
Installing Upholstery .....	4
Electrical Requirements .....	5
Headrest Adjustment Tools .....	5
<b>DESCRIPTION .....</b>	<b>5</b>
Introduction .....	5
Features .....	6
<b>COMPONENTS OVERVIEW .....</b>	<b>7</b>
<b>CONTROLS AND INDICATORS .....</b>	<b>8</b>
<b>OPERATION .....</b>	<b>10</b>
Foot Control Positioning and Use .....	10
Back Section Positioning .....	11
Table Top Height Positioning .....	12
Tilt Function Positioning (Table Top Angle) .....	13
Foot Section Positioning .....	14
Procto Knee Rest Positioning .....	15
Stirrup Positioning .....	16
Irrigation Pan Use (Optional) .....	17
Paper Roll Installation .....	18
Headrest Removal / Installation .....	18
Headrest Positioning .....	19
Accessory Rails (Optional) .....	20
List of Authorized Accessories .....	20
Patient Positioning .....	21
<b>OPERATOR MAINTENANCE .....</b>	<b>21</b>
Preventive Maintenance .....	21
Cleaning .....	21
Headlock Assembly Adjustment .....	22
Headlock Handle Stops Adjustment .....	23
<b>CALLING FOR SERVICE .....</b>	<b>24</b>
<b>SPECIFICATIONS .....</b>	<b>24</b>
<b>LIMITED WARRANTY .....</b>	<b>26</b>

## IMPORTANT INFORMATION

### Scope and Purpose of This Manual

This manual covers complete instructions for the installation, operation, and normal care of the Model 319 Power Examination Table. It is intended that this manual be used by any medical personnel responsible for operating the examination table during a medical procedure or performing operator level maintenance.

### Intended Use of Product

This product is intended for use in examination / procedure environments where patient positioning is required to accomplish general medical examinations and / or procedures.

### Safety Instructions

The primary concern of Midmark is that this equipment is operated and maintained with the safety of the patient and staff in mind. To assure safer and more reliable operation:

- Read and understand this manual before attempting to install or operate the table.
- Assure that appropriate personnel are informed on the contents of this manual; this is the responsibility of the purchaser.
- Assure that this manual is located near the table, or if possible, permanently affixed to the table.

### Explanation of Safety Symbols and Notes



#### **DANGER**

Indicates an imminently hazardous situation which, if not avoided, will result in death or serious injury. The **DANGER** symbol is limited to the most extreme situations.



#### **WARNING**

Indicates a potentially hazardous situation which, if not avoided, could result in death or serious injury.

**CAUTION**

Indicates a potentially hazardous situation which, if not avoided, may result in minor or moderate injury. It may also be used to alert against unsafe practices.

**EQUIPMENT ALERT**

Indicates an imminently or potentially hazardous situation which, if not avoided, will or may result in serious, moderate, or minor equipment damage.

**NOTE**

Amplifies an operating procedure, practice, or condition.

## INSTALLATION

### Unpacking

**EQUIPMENT ALERT**

To avoid damaging the table, do not use a knife or other sharp object to open the table's packaging. Also, to avoid damaging the table, do not lift at points (1, Figure 2).

Carefully remove the packaging from the table and foot control, and then inspect the table for any shipping damage. Report any damage to the shipping company and fill out a concealed damage report.

Unbolt the table from the wooden shipping skid by removing four bolts (2, Figure 2) from the underside of the table's base.

**WARNING**

**The table weighs approximately 460 lbs (208.6 kgs). Get an assistant to help remove the table from the shipping skid. Also, use proper lifting techniques when lifting table. Failure to do so could result in serious back injury.**

After unbolting, remove the table from the shipping skid (3), lifting at points (4 and 5). **Do not** lift at points (1); these are unsupported areas. Position the table in room as desired.

On tables with an irrigation pan assembly, pull out irrigation pan slide (6) and remove packing tape from the drain pan assembly components. Return irrigation pan slide (6) to its stowed position.

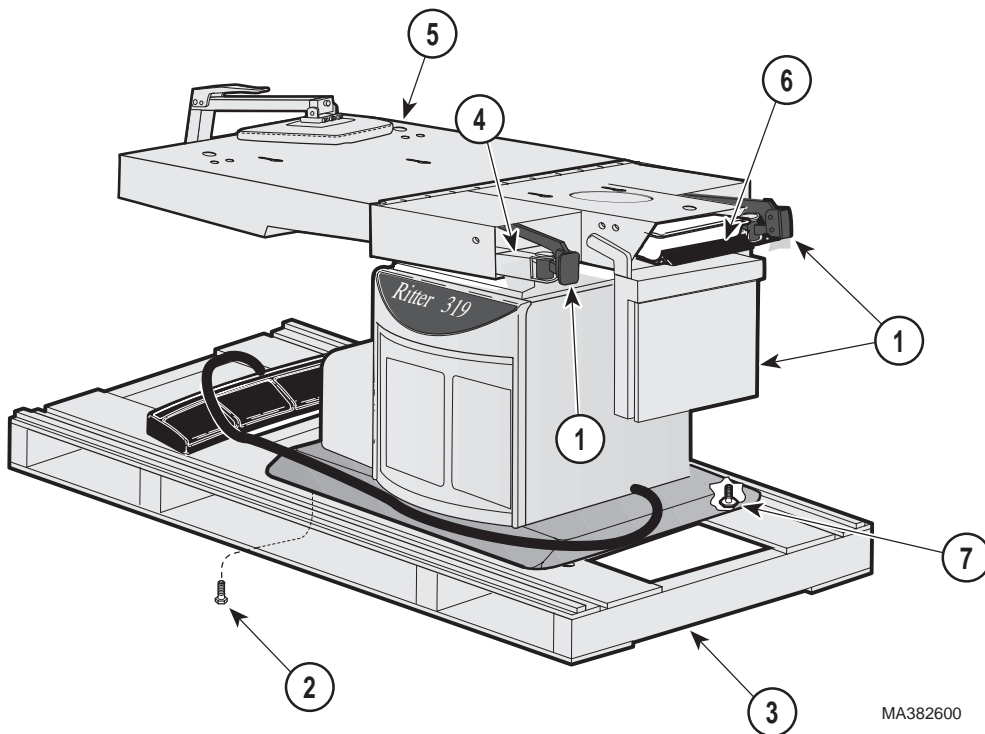

MA382600

**Figure 2. Table Installation**

## Leveling The Table

A leveling screw pad (7, Figure 2) is located under each corner of the table's base. Adjust the four leveling screw pads (7) up or down (by turning them) until a solid, level installation is achieved.

## Installing Upholstery

### **NOTE**

The table is shipped without upholstery. The upholstery for the table comes as a separately packaged kit.

Refer to the upholstery installation instructions provided with the upholstery kit to install the upholstery on the table.

## Electrical Requirements



### WARNING

All exposed metal parts of the table are electrically grounded. When performing a cauterization or similar treatment, the patient must be insulated from the metal portions of the table by nonconductive material. Failure to do so could result in electrical shock or burns to the patient.

Use only 115 VAC, 60 HZ alternating current for 115 VAC units and use only 230 VAC, 50/60 HZ alternating current for 230 VAC units. Failure to do so could result in electrical shock to personnel and will result in damage to table.

The electrical rating for the 115 VAC version of the Model 319 Power Examination Table is 115 VAC, 60 Hz, 12 amps. The electrical rating for the 230 VAC version of the Model 319 Power Examination Table is 230 VAC, 50/60 Hz, 6.3 amps. The three-pronged grounding plug on the table power cord must be plugged into a matching three-pronged, grounded, non-isolated, correctly polarized receptacle. The single table power cord provides power for all electrical functions of the table.

## Headrest Adjustment Tools

The wrenches necessary to adjust the headlock assembly have been provided. These wrenches are in a bag which has been attached to the headlock assembly of the table. Remove this bag of wrenches (includes a 3/16", 3/32", 1/8", and 5/32" Allen Wrench and a head lock wrench) before using the table and store these tools with the Installation & Operation Manual.

## DESCRIPTION

### Introduction

The 319 Power Examination Table is primarily used in examination rooms for general examinations and minor procedures. The combinations of its four powered motions, adjustable procto knee rest, stirrups, optional irrigation pan, and adjustable headrest provide a table which can be tailored to facilitate most examinations and treatments being performed in a doctor's office. The 319 is designed to reduce effort and fatigue, and increase safety involved in the examination and treatment of patients. A hydraulic power unit is used to provide the necessary power to move the four powered motions. There are many other features which are listed as follows:

Installation

Description

## Features

The Model 319 Power Examination Table has . . .

- powered positioning of its four table top motions; back up and down, tilt up and down, foot up and down, and table up and down.
- a hydraulic power unit which supplies hydraulic power to provide movement for the table's four powered motions.
- a four station footswitch which provides the operator with easy-to-use controls for positioning the table's four powered functions, yet do not require breaking the sterile field.
- a manually adjustable head rest which may be adjusted to allow the operator to position the patient's head in a specific position or orientation.
- a manually adjustable foot rest which may be adjusted into a procto knee rest position for proctologic examinations.
- right and left stirrups which can be extended to an infinite number of positions as well as laterally in three positions.
- optional accessory rails which allow use of mounted accessories with table.
- an optional irrigation pan assembly which allows table to be used with procedures requiring irrigation.
- a decorative colored insert panel which can be changed to a new color if desired.
- a styled upholstery top which is designed with quick release locking clips that allow the upholstery to be removed / installed very quickly and easily without the need for tools **or** one of four optional upholstery kits: a narrow, sewn upholstery top, a sewn upholstery top, a styled, sewn upholstery top, or a styled, seamless upholstery top.
- a paper roll holder which is hidden in the head end of the back section and paper tear strips, located at the foot end and head end of the upholstered top, to secure examination paper during a patient examination or procedure.

### Description

# COMPONENTS OVERVIEW

The illustration below (Figure 3) shows the location of the table's major components and the chart below provides their descriptive name.

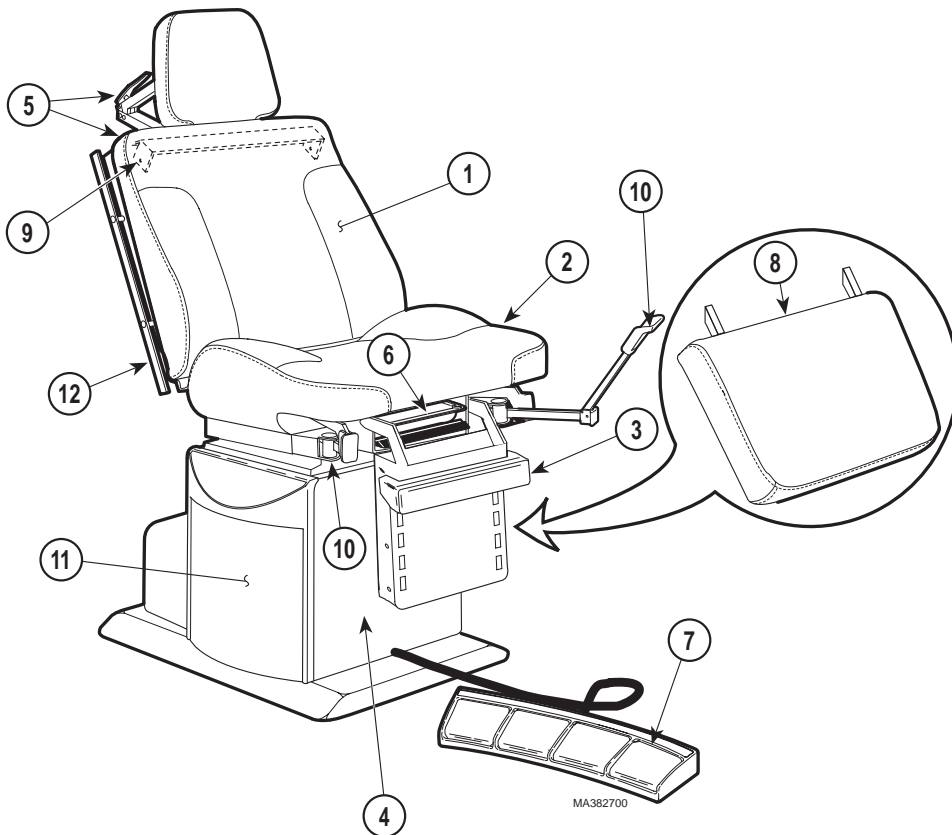

**Figure 3. Components Overview**

## DESCRIPTION OF COMPONENTS

1. Back Section (adjustable angle)	7. Foot Control
2. Seat Section (adjustable angle)	8. Procto Knee Rest
3. Foot Section (adjustable angle)	9. Paper Roll Holder
4. Column Assy (adjustable height)	10. Stirrups
5. Headrest Assembly	11. Decorative Panel
6. Treatment Irrigation Pan (optional on some units - if not, may be purchased as an accessory).	12. Accessory Rails (optional on some units - if not, may be purchased as an accessory)

Description

Components Overview

# CONTROLS & INDICATORS

The illustration below (Figure 4) shows the location of the table's controls and indicators and the chart below describes their function.

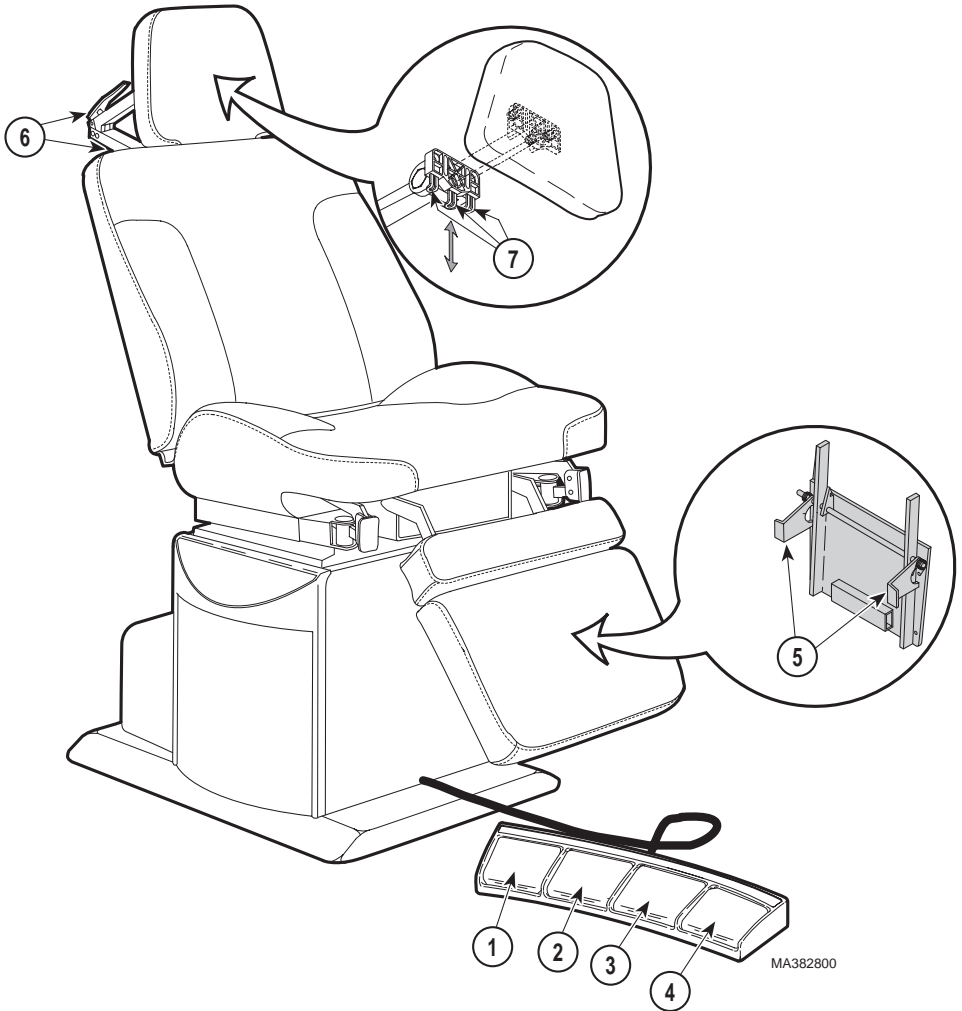

Figure 4. Controls and Indicators

Ref.	Control	Function
1	TABLE UP / TABLE DOWN pedal	when depressed toward left, raises the table top upward. When depressed toward right, lowers the table top downward.

<b>Ref.</b>	<b>Control</b>	<b>Function</b>
<b>2</b>	<i>BACK UP / BACK DOWN pedal</i>	<i>when depressed toward left, raises the back section upward toward the chair position. When depressed toward right, lowers the back section downward toward the horizontal position.</i>
<b>3</b>	<i>TILT UP / TILT DOWN pedal</i>	<i>when depressed toward left, tilts the front of the seat section upward (tilting the entire table top). When depressed toward right, lowers the front of the seat section downward.</i>
<b>4</b>	<i>FOOT UP / FOOT DOWN pedal</i>	<i>when depressed toward left, the foot section raises upward (toward the horizontal position). When depressed toward right, the foot section lowers downward (toward the vertical position).</i>
<b>5</b>	<i>Foot Rest Release handles</i>	<i>used to release foot rest so it may be removed from table for repositioning.</i>
<b>6</b>	<i>Head Lock handles</i>	<i>used to unlock the headlock assembly so it may be positioned and then relocked in the desired position.</i>
<b>7</b>	<i>Headrest releases</i>	<i>three quick releases are used to quickly remove headrest from headlock assembly so it may be replaced with a different type headrest.</i>

## OPERATION



### WARNING

Do not use this table in an explosive or oxygen-rich atmosphere. To do so could result in an explosion or fire.

## Foot Control Positioning and Use



### WARNING

The foot control is moisture resistant to aid in eliminating foot control shock hazards. However, the foot control uses standard line voltages. To avoid electrical shock, do not immerse the foot control in water / fluids.



### CAUTION

Keep foreign objects away from the foot control. Also, be sure foot control is not positioned below the foot section or headlock assembly of the table so that the pedals of foot control are not inadvertently activated. Failure to do so could result in a frightened patient and / or damage to table.



### EQUIPMENT ALERT

The foot control is moisture resistant to aid in eliminating foot control shock hazards. However, to avoid temporary / permanent damage to the foot control, avoid immersing the foot control in water / fluids.

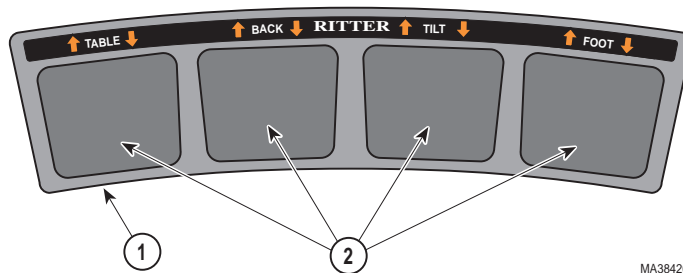

MA384200

Place the foot control (1) where it will not be in the way of other staff members, but can easily be reached by the operator. With a firm stance, place your foot on the footswitch rocker (2) for the desired function. Tilting your foot to the left activates the function in the UP direction. Tilting your foot to the right activates the function in the DOWN direction. Hold the footswitch rocker down until the desired position is achieved or the function reaches the end of its travel and stops moving. Remove your foot from the foot control when table positioning is completed. A more detailed description of each of the foot control functions is included throughout the remainder of this section.

## Back Section Positioning

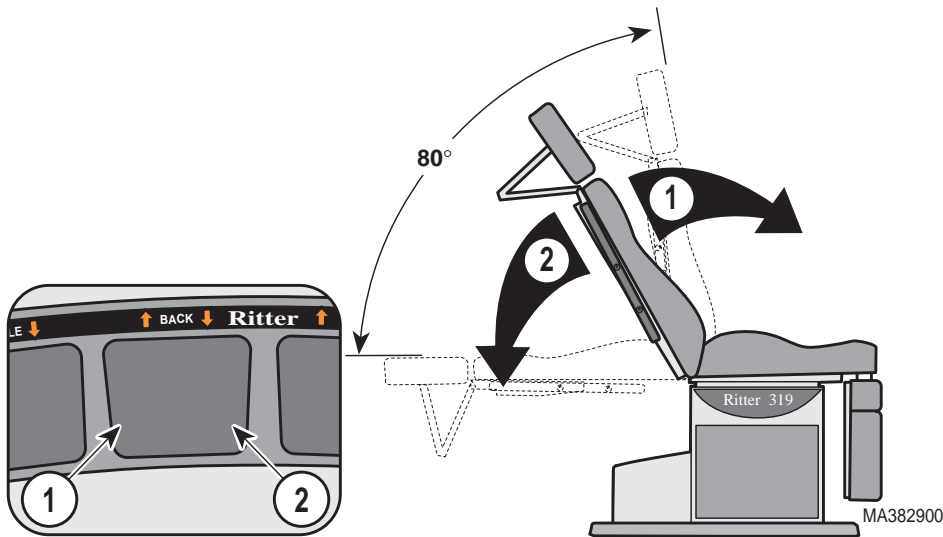

### EQUIPMENT ALERT

The back section will stop moving when either the UP or Down travel limit is reached, but the hydraulic motor will continue to run until the foot pedal is released. Do not continue to operate a function that has reached its limit; this will cause the hydraulic motor to overheat and may reduce the life of the motor.

The back section can be positioned at any angle between horizontal ( $0^\circ$ ) and the chair position  $+80^\circ \pm 5^\circ$ . To adjust the back section from a horizontal to a chair position, depress and hold the BACK UP pedal (1) until the back section reaches the desired angle or the chair position is achieved. To adjust the back section from a chair position to a horizontal position, depress and hold the BACK DOWN pedal (2) until the back section reaches the desired angle or the horizontal position is achieved.

Operation

## Table Top Height Positioning

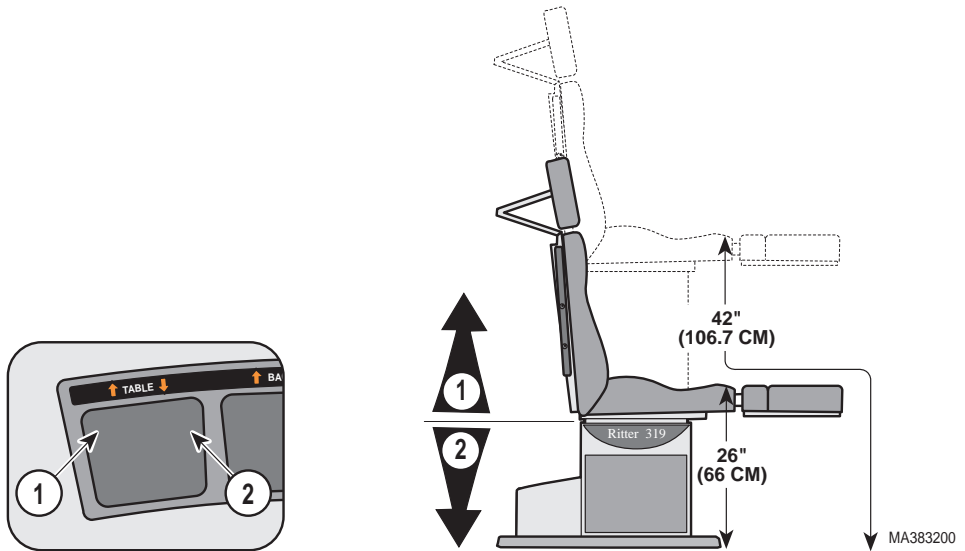

### Operation



#### EQUIPMENT ALERT

The table top will stop moving when either the Up or Down travel limit is reached, but the hydraulic motor will continue to run until the foot pedal is released. Do not continue to operate a function that has reached its limit; this will cause the hydraulic motor to overheat and may reduce the life of the motor.

The table top can be positioned at any height between 26.0 in. (66.0 cm) minimum and 42.0 in. (106.7 cm) maximum. To adjust the table top upward, depress and hold the TABLE UP pedal (1) until the table top reaches the desired height or the maximum height is achieved. To lower the table top downward, depress and hold the TABLE DOWN pedal (2) until the table top reaches the desired height or the minimum height is achieved.

## Tilt Function Positioning (Table Top Angle)

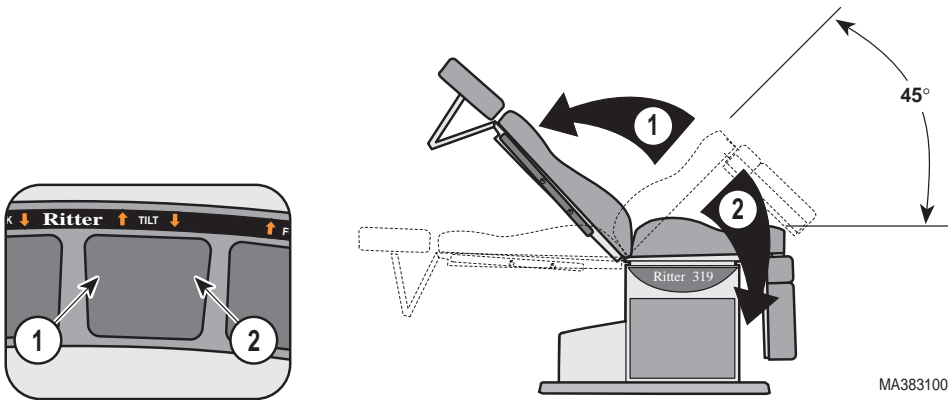

### EQUIPMENT ALERT

The table top will stop moving when either the Up or Down travel limit is reached, but the hydraulic motor will continue to run until the foot pedal is released. Do not continue to operate a function that has reached its limit; this will cause the hydraulic motor to overheat and may reduce the life of the motor.

The plane of the table top can be positioned at any angle between horizontal and +45° (foot up). To tilt the foot end of the table top upward, depress and hold the TILT UP pedal (1) until the table top reaches the desired angle or the maximum downward tilt is achieved. To tilt the foot end of the table downward, depress and hold the TILT DOWN pedal (2) until the table top reaches the desired angle or the horizontal position is achieved.

Operation

## Foot Section Positioning

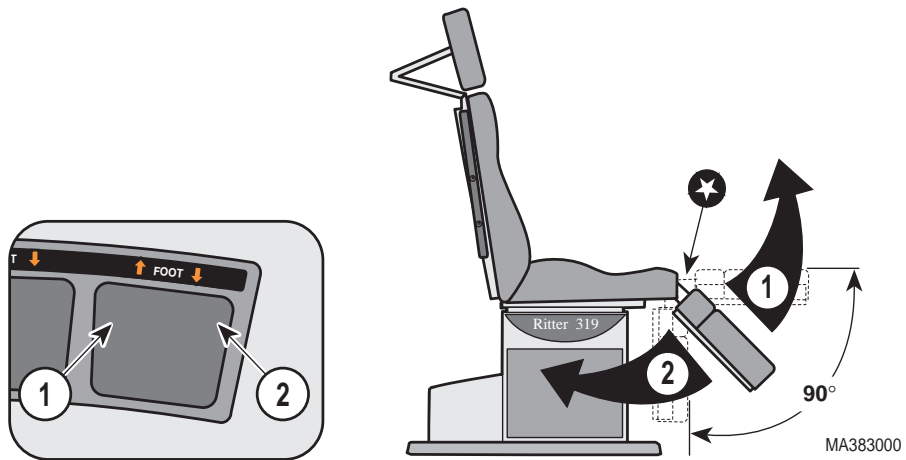

### EQUIPMENT ALERT

The table top will stop moving when either the Up or Down travel limit is reached, but the hydraulic motor will continue to run until the foot pedal is released. Do not continue to operate a function that has reached its limit; this will cause the hydraulic motor to overheat and may reduce the life of the motor.

### NOTE

A safety switch prevents operation of the FOOT UP and FOOT DOWN functions when the optional irrigation pan slide (★) is extended; this prevents the foot section from colliding with the irrigation pan slide. If the FOOT UP and FOOT DOWN functions are not operable, check to ensure that the irrigation pan slide is fully stowed. A light clicking sound will be heard just before the irrigation pan slide reaches its fully stowed position.

The foot section can be positioned at any angle between horizontal (0°) and -90°. To raise the foot section from a vertical position to a horizontal position, depress and hold the FOOT UP pedal (1) until the foot section reaches the desired angle or the horizontal position is achieved. To lower the foot section from a horizontal position to a vertical position, depress and hold the FOOT DOWN pedal (2) until the foot section reaches the desired angle or the vertical position is achieved.

## Procto Knee Rest Positioning

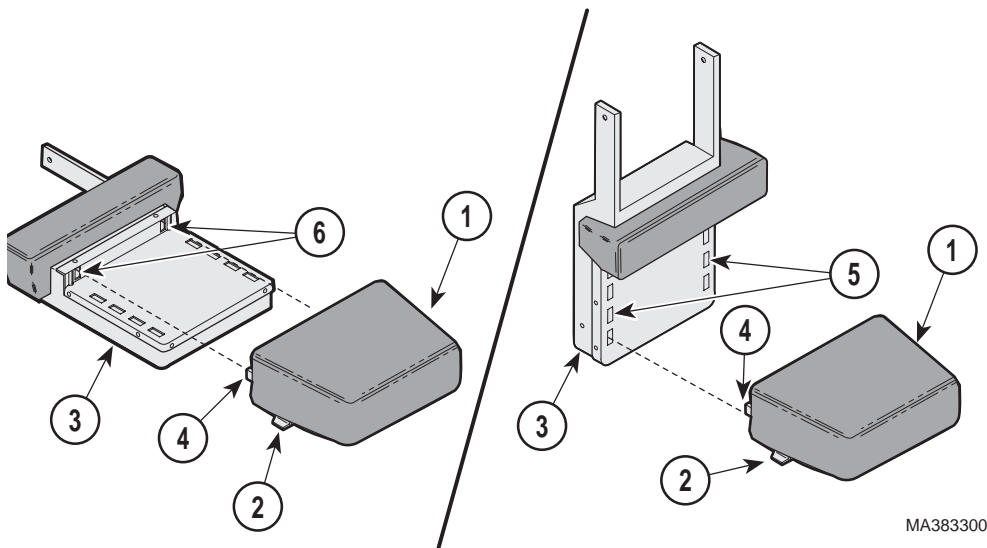

There are four different height positions in which the procto knee rest (1) can be set for.

**To remove the procto knee rest**, lift release levers (2) on each side of procto knee rest (1) and pull procto knee rest straight away from table.



### CAUTION

Make sure the procto knee rest is securely latched in place before using with patient. Failure to do so could result in serious personal injury.

**To position the procto knee rest**, depress the Foot Down button and lower the foot section (3) down all the way. Then, insert the metal guides (4) of procto knee rest (1) into one of the four procto knee rest positions (5) provided until the mechanical locking hooks can be seen or heard to engage. Pull on the procto knee rest (1) to ensure that it is securely latched in place.

**To return the procto knee rest to its stowed position**, lift release levers (2) on each side of procto knee rest (1) and pull knee rest out of procto knee rest position (5). Then, insert the metal guides (4) of procto knee rest (1) into foot rest slots (6). Pull on the procto knee rest to ensure that it is securely latched in place.

Operation

## Stirrup Positioning

**To erect the stirrup**, grasp end of stirrup and pull stirrup straight out of table to full extension. Unfold stirrup upward to an erect position.

### NOTE

If you are applying any downward pressure on the end of the stirrup when sliding it in or out, it may be very difficult to move. This is normal and is part of the stirrup extension locking mechanism. For ease of movement, lift up slightly while sliding the stirrup in or out.

**To adjust the stirrup extension length**, hold the end of the stirrup and slide in or out until the desired extension is achieved.



### WARNING

Failure to engage the lateral locking mechanism could allow patient to lose balance resulting in personal injury to patient.

**To adjust the lateral position of a stirrup**, lift end of stirrup and then rotate stirrup to the right or left into one of the three possible lateral positions. The stirrup will click into each position as it is rotated. When the desired position is attained, lower stirrup to engage the lateral locking mechanism. Check that lateral locking mechanism is engaged by attempting to rotate stirrup assembly without lifting on stirrup end.

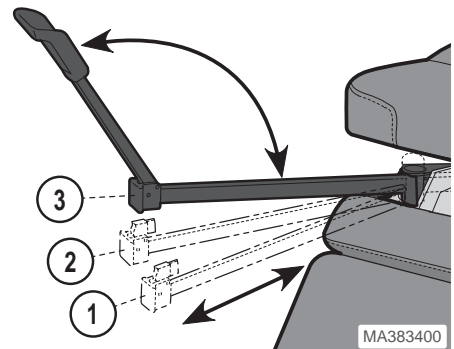

**To return stirrup to storage**, grasp end of stirrup and pull stirrup straight out to full extension. Fold stirrup down against bar, rotate stirrup to lateral position 1, and then slide stirrup back into stowed position.

## Irrigation Pan Use (Optional)

### NOTE

A safety switch prevents operation of the FOOT UP and FOOT DOWN functions when the irrigation pan slide (2) is extended; this prevents the foot section from colliding with the irrigation pan slide. If the FOOT UP and FOOT DOWN functions are not operable, check to ensure that the irrigation pan slide is fully stowed. A light clicking sound will be heard just before the irrigation pan slide reaches its fully stowed position.

**To expose the irrigation pan (1) for use**, grasp the irrigation pan slide handle (2) and pull until pan slide is fully extended.

**To clean the irrigation pan (1)**, the irrigation pan (1) can easily be removed for cleaning when the irrigation pan slide (2) is fully extended. To replace the irrigation pan (1), align pan and then press pan firmly into pan slide (2).

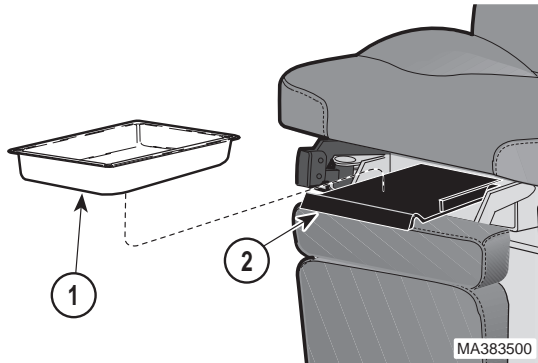

**To stow the irrigation pan (1) after use**, push in on irrigation pan slide handle (2) as far as it will go. A light clicking sound just before the irrigation pan slide reaches its fully stowed position indicates that the pan slide (2) is properly stowed.

Operation

## Paper Roll Installation

Storage for a 21 in. wide x 3.5 in. diameter (53.3 x 8.9 cm) paper roll (1) is provided under the upper portion of the back section.

**To install a paper roll,** rotate the paper cover (2) out of way (it is recommended to have the back section in a horizontal position). Place a paper roll (1) into paper roll cavity (3) as shown, and then rotate paper cover (2) back into position to hold paper roll in place. Pull the paper over table top and feed the paper under two retaining straps (4). New paper may now be pulled out quickly and easily for each patient.

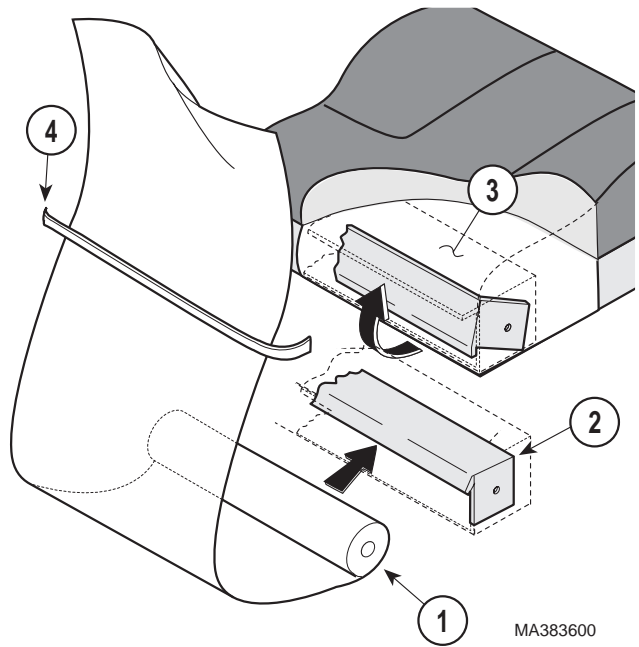

## Operation

## Headrest Removal / Installation

The headrest can be removed or exchanged with another headrest to facilitate a variety of procedures.

**To remove a headrest,** pull the three retaining latches (1) outward and then pull up on the headrest (2) to release the headrest from the headrest mount (3).

**To install a headrest,** align the three headrest studs (4) with headrest mount (3) and then push the headrest firmly onto the headrest mount. Secure the headrest (2) by pushing the three retaining latches (1) inward until they are latched.

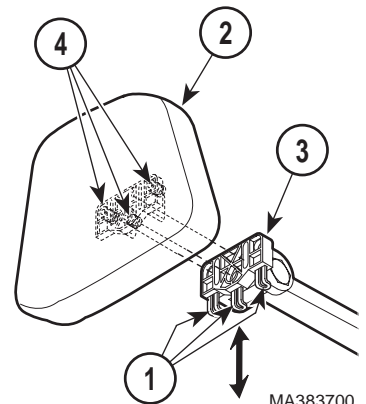

## Headrest Positioning



### WARNING

Make sure headrest is securely locked into position before use. Failure to have the upper and lower handles correctly locked could result in headrest falling during a procedure. This could cause serious personal injury.

Upper handle (1) and lower handle (2) are used to control the positioning of the headrest by locking and unlocking three rotational joints (3, 4, and 5) of the headlock assembly.

**To position the headrest (6),** grasp upper handle (1) and pull it outward. This releases tension at joints (3 and 4). Position upper arm and headrest as desired; then push inward on upper handle (1) to lock joints (3 and 4) in place.

Grasp the lower handle (2) and pull it outward. This releases tension at joint (5). Position lower arm as desired; then push inward on lower handle (2) to lock joint (5) in place. Repeat these steps until the headrest (6) is positioned as desired. Make sure upper and lower handles (1 and 2) are locked correctly (a handle is locked correctly when it is pushed past center and the force of the clamping action pulls the handle into locked position and holds it there).

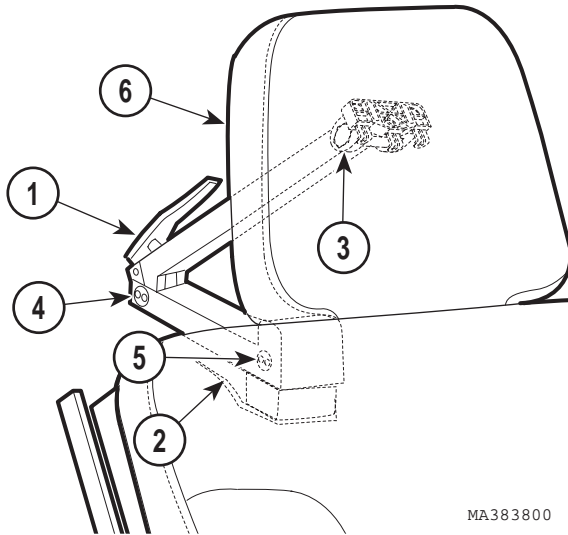

MA383800

Operation

## Accessory Rails (Optional)

A 3/8 in. wide (9.5 mm) x 1 in. (25.4 mm) tall accessory rail (1) is located along each side of the back section for mounting of authorized accessories.

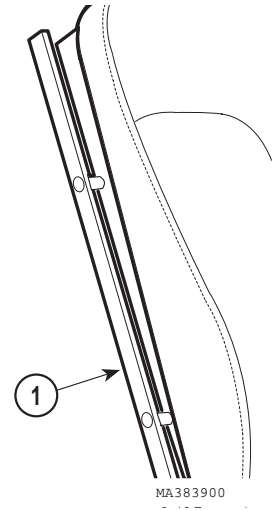

## List of Authorized Accessories

Listed below are the accessories which are authorized for use with the table.

<u>Accessory Name</u>	<u>Order Number</u>	
• Chair Arms	9A4300X	
• Facial Pad	9A5100X	
• Restraint Straps	9A6000X	
• Accessory Rails	9A6700X	
• Irrigation Pan	9A6800X	
• Caster Base	9A7500X	
• I.V. Pole	9A7700X	
• Vision Screen	9A7800X	
• Armboard	9A8100X	
• Armboard	9A8200X	
• Instrument Tray	9A8300X	
• Knee Crutches	9A14700X	
• Side Rails	9A15700X	
• Armboard	9A17900X	
• Base Rails	9A18400X	(Do not use simultaneously with 9A22800X, Seat Rail Accessory)
• Welch Allyn Bracket	9A18400X	
• Caster Base	9A19700X	
• Special Headrest-Round	9A19800X	
• Special Headrest-Surgery	9A19900X	
• Color Panels	9A20000X	
• Knee Crutches	9A20900X	
• Wrist Support - Single	9A22100X	
• Wrist Support - Double	9A22200X	
• Seat Rail	9A22800X	(Do not use simultaneously with 9A18400X, Base Rails Accessory)

## Patient Positioning

The table is designed to accommodate the following examination positions:

- Full Flat Table Position
- Chair Position
- Lithotomy (pelvic position)
- Knee-Chest
- Semi-Reclining
- Fowler
- Trendelenburg

## OPERATOR MAINTENANCE

### Preventive Maintenance

Little routine maintenance is required other than periodic inspection of the electrical cord, foot control cord, and hydraulic hoses to ensure they are free of cuts or damage, periodic inspection of the mechanical functions to ensure satisfactory operation, and periodic check of fasteners to ensure they are present and tightened securely.

Have your authorized dealer inspect your table every six months.

Oil moving parts (such as back hinge, irrigation pan slides, and the stirrup indexing pivot) with a light machine oil to assure quiet, smooth, and dependable operation. Stirrup bars and accessory rails can be lubricated using common household furniture wax.

### Cleaning

#### Upholstery



#### **EQUIPMENT ALERT**

The upholstery material that covers the top of the table is resistant to most medicinal-type stains, but may be damaged by solvents and dyes. Remove any fluids which are spilled on the upholstery immediately.

Clean the table weekly, wiping the painted metal and plastic surfaces with a clean, soft cloth. If desired, mild cleaners may be used. Periodic applications of common furniture wax will ease cleaning and help to maintain the finished luster of the table.

Operation

Operator  
Maintenance

## Headlock Assembly Adjustment

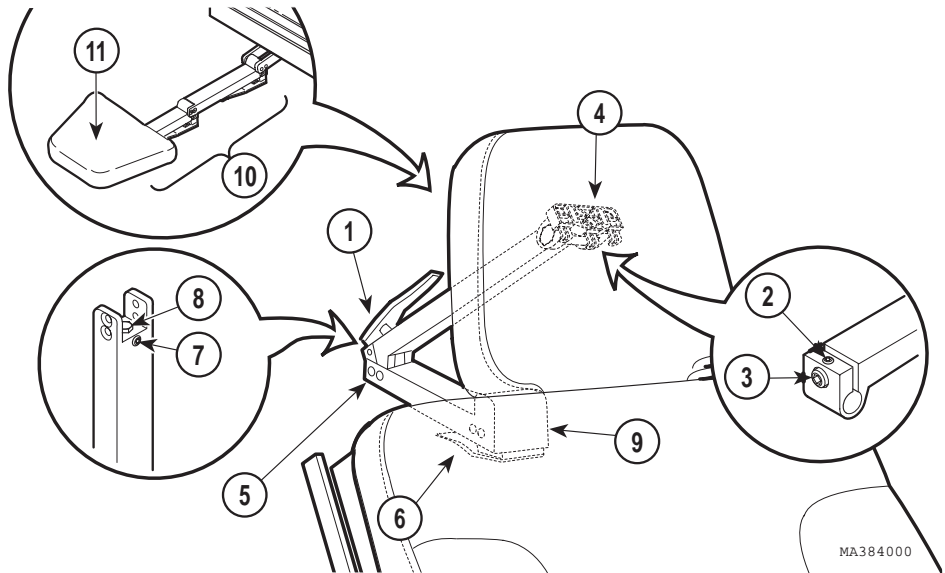

The wrenches necessary to adjust the headlock assembly have been provided. These wrenches are in a bag which has been attached to the headlock assembly of the table. Remove this bag of wrenches before using the table and store these tools with the Installation & Operation Manual.



### WARNING

Failure to adjust the headlock assembly to specifications could result in a failure during a procedure. This could cause severe personal injury to a patient or the need to terminate the procedure.

### NOTE

The maximum force required to unclamp a locking handle should be 17 lbs. (7.7 kgs) and the maximum force required to clamp a locking handle should be 35 lbs. (15.8 kgs).

1. Unlock upper lock handle (1); then loosen setscrew (2).
2. Tighten adjusting screw (3) slightly; then lock upper lock handle (1). Repeat this step until joints (4 and 5) have the strongest possible holding power, but operation of upper lock handle (1) is not too difficult. Then, tighten setscrew (2).

3. Unlock lower lock handle (6); then loosen setscrew (7).
4. Tighten adjusting screw (8) slightly; then lock lower lock handle (6). Repeat this step until joint (9) has the strongest possible holding power, but operation of lower lock handle is not too difficult. Then, tighten setscrew (7).
5. Lower Back Down function all the way down.
6. Position the headlock assembly (10) in fully extended position. Then, place a 45 lb. (20.4 kg) weight on the center of headrest (11).
7. Observe. The headlock assembly (10) should support the test weight without drifting downward. If not, repeat entire adjustment procedure. If headlock assembly (10) does not meet test standards, do not use the headlock assembly.

## Headlock Handle Stops Adjustment

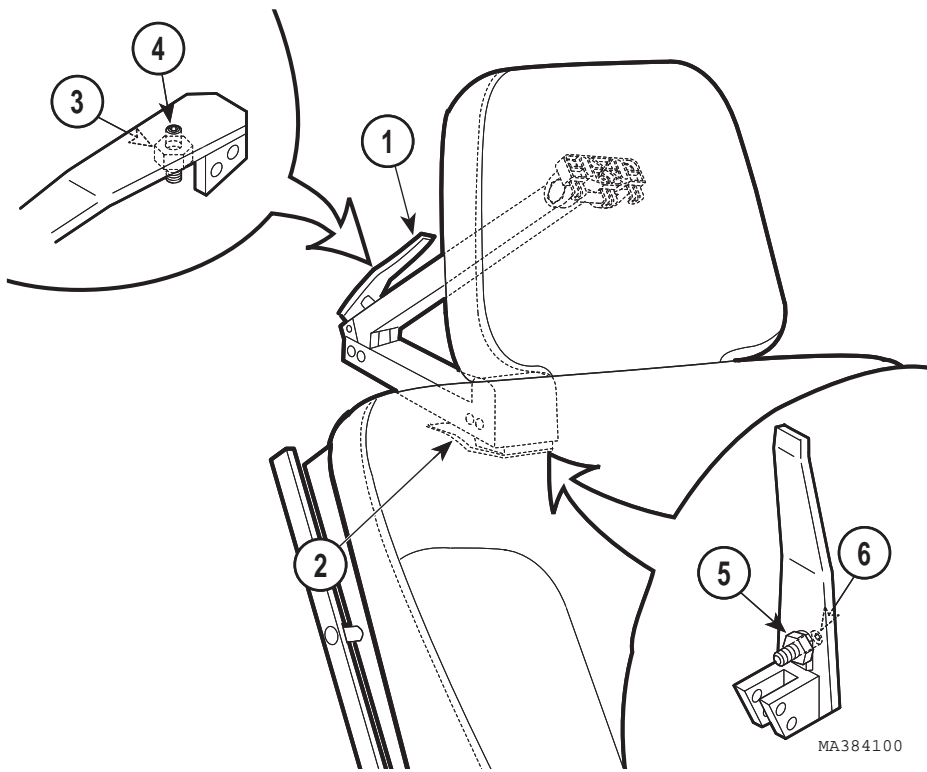

If either the upper lock handle (1) or the lower lock handle (2) fails to lock by “going over center” or if there is not enough finger clearance between the headlock assembly and the handle, perform the following adjustment:

1. Loosen nut (3).
2. Push on upper lock handle (1) until it reaches a point where the upper lock handle wants to lock itself by going over center; then allow the upper lock handle to go over center a few degrees. Hold the upper lock handle (1) in this position and adjust stop screw (4) so the upper lock handle will be forced to stop in this position each time it is locked. Then, tighten nut (3).
3. Loosen nut (5).
4. Push on lower lock handle (2) until it reaches a point where the lower lock handle wants to lock itself by going over center; then allow the lower lock handle to go over center a few degrees. Hold the lower lock handle (2) in this position and adjust stop screw (6) so the lower lock handle will be forced to stop in this position each time it is locked. Then, tighten nut (5).

## **CALLING FOR SERVICE**

If you are having a problem or have a question, refer to the inside front cover of this manual and call your dealer. Make sure that you have the information that is highlighted on the inside front cover of this manual available. If you can't resolve your question or problem with your dealer, call the following number:

1-800-Midmark (1-800-643-6275)

8:00 a.m until 5:00 p.m. (Eastern Standard time in the U.S.)

Monday thru Friday, except for standard U.S. holidays.

## **SPECIFICATIONS**

**Patient Weight (Maximum):**.....325 lbs (147.4 kgs)

**Weight of Table:**.....460 lbs (208.6 kgs)

**Back Section Range:**.....0° (horizontal) to 80° (±5°)

**Table Top Tilt Range:** .....0° (horizontal) to 45° (±5°)

**Foot Section Range:** .....0° (horizontal) to -90° (±3°)

**Table Top Height Range:**.....26.0 in. (minimum) to 42.0 in. (maximum)  
(66.0 cm to 106.7 cm)

**Operator  
Maintenance**

**Calling For  
Service**

**Specifications**

**Dimensions:**

Upholstered Top (overall) ..... 27.0 in. wide x 70.0 in. long  
(68.6 cm x 177.8 cm)

With Narrow Upholstery (Optional) . 24.0 in. wide (60.9 cm)

With Headrest Extended ..... up to 80.0 in. long (203.2 cm)

Base ..... 23.0 in. x 31.0 in. x 1.69 in. high  
(58.4 cm x 78.7 cm x 4.3 cm)

**Electrical Requirements:**

115 VAC Unit..... 115 VAC nominal (126 VAC maximum - 110  
VAC minimum), 60 HZ, 12.0 amps

230 VAC Unit..... 230 VAC (253 VAC maximum - 207 VAC  
minimum), 50/60 Hz, 6.3 amps

**Paper Roll:** ..... Can accept a paper roll up to 21 in. x  
3.5 in. (53.3 cm x 8.9 cm)

**Power Cord:** ..... extends 96 in. (243.8 cm) (Minimum) from  
table. 12 AWG / 3 conductor, SJT grey  
jacketed junior hard service with hospital  
grade grounding type plug.

**Certifications:** ..... U.L Listed Medical Equipment  
(115 VAC Units Only)  
C.U.L. listed to CSA Standard C22.2 #125  
(115 VAC Units only)  
ISO-9001 Certified

**Operator  
Maintenance**

**Calling For  
Service**

**Specifications**

## **LIMITED WARRANTY**

### **SCOPE OF WARRANTY**

Midmark Corporation ("Midmark") warrants to the original purchaser its new Alternate Care products and components (except for components not warranted under "Exclusions") manufactured by Midmark to be free from defects in material and workmanship under normal use and service. Midmark's obligation under this warranty is limited to the repair or replacement, at Midmark's option, of the parts or the products the defects of which are reported to Midmark within the applicable warranty period and which, upon examination by Midmark, prove to be defective.

### **APPLICABLE WARRANTY PERIOD**

The applicable warranty period, measured from the date of delivery to the original user, shall be one (1) year for all warranted products and components.

### **EXCLUSIONS**

This warranty does not cover and Midmark shall not be liable for the following: (1) repairs and replacements because of misuse, abuse, negligence, alteration, accident, freight damage, or tampering; (2) products which are not installed, used, and properly cleaned as required in the Midmark "Installation" and or "Installation / Operation Manual for this applicable product. (3) products considered to be of a consumable nature; (4) accessories or parts not manufactured by Midmark; (5) charges by anyone for adjustments, repairs, replacement parts, installation, or other work performed upon or in connection with such products which is not expressly authorized in writing in advance by Midmark.

### **EXCLUSIVE REMEDY**

Midmark's only obligation under this warranty is the repair or replacement of defective parts. Midmark shall not be liable for any direct, special, indirect, incidental, exemplary, or consequential damages or delay, including, but not limited to, damages for loss of profits or loss of use.

### **NO AUTHORIZATION**

No person or firm is authorized to create for Midmark any other obligation or liability in connection with the products.

**THIS WARRANTY IS MIDMARK'S ONLY WARRANTY AND IS IN LIEU OF ALL OTHER WARRANTIES, EXPRESS OR IMPLIED. MIDMARK MAKES NO IMPLIED WARRANTIES OF ANY KIND INCLUDING ANY WARRANTIES OF MERCHANTABILITY OR FITNESS FOR ANY PARTICULAR PURPOSE. THIS WARRANTY IS LIMITED TO THE REPAIR OR REPLACEMENT OF DEFECTIVE PARTS.**

SF-1487 REV. A1

**NOTES:**

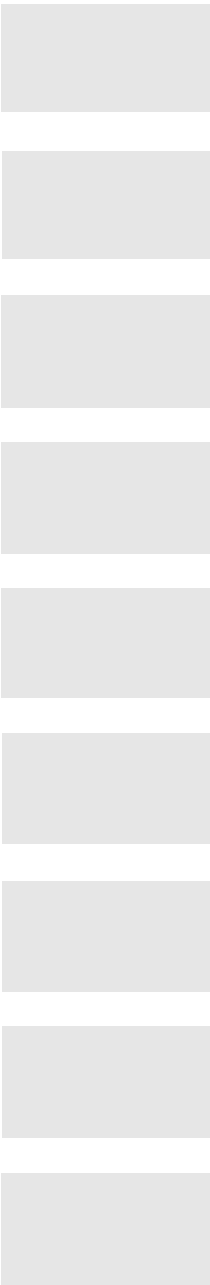

**Limited  
Warranty**

**NOTES:**





**MIDMARK<sup>®</sup>**

Midmark Corporation, Versailles, Ohio 45380 U.S.A.  
937-526-3662 FAX: 937-526-5542

© Midmark Corporation - 1997

003-0851-00 Rev. A (6/97)